

Interface Abilities 

Interface + 1d10 vs. DV

SCANNER: use a Meat Action to find out the Meatspace location of access points.

BACKDOOR: break through Passwords

CLOAK: hide traces of your presence or Virus

CONTROL: control things attached to the NET Architectures

EYE-DEE: identify a found piece of data

PATHFINDER: reveal partially the "map" of the NET Architecture

SLIDE: attempt to flee combat with a single Non-Demon Black ICE Program

VIRUS: place a Virus on the lowest level

ZAP: deal 1d6 damage to a Program or Netrunner

Icons by game-icons.net Circuit designed by Freepik

PROGRAM REZZED

ERASER 

PROGRAM USED PROGRAM DEREZED



PER	SPD	ATK	DEF	REZ
-	-	0	0	7

Increases all Cloak Checks you make by +2 as long as this Program remains Rezzed.

Cost: 20eb Page 203

Icons by game-icons.net Circuit designed by Freepik

PROGRAM REZZED

SEE YA 

PROGRAM USED PROGRAM DEREZED



PER	SPD	ATK	DEF	REZ
-	-	0	0	7

Increases all Pathfinder Checks you make by +2 as long as this Program remains Rezzed.

Cost: 20eb Page 203

Icons by game-icons.net Circuit designed by Freepik

PROGRAM REZZED

SPEEDY GONZALVEZ 

PROGRAM USED PROGRAM DEREZED



PER	SPD	ATK	DEF	REZ
-	-	0	0	7

Increases your Speed by +2 as long as this Program remains Rezzed.

Cost: 100eb Page 203

Icons by game-icons.net Circuit designed by Freepik

PROGRAM REZZED

WORM 

PROGRAM USED PROGRAM DEREZED



PER	SPD	ATK	DEF	REZ
-	-	0	0	7

Increases all Backdoor Checks you make by +2 as long as this Program remains Rezzed.

Cost: 50eb Page 203

Icons by game-icons.net Circuit designed by Freepik

PROGRAM REZZED

ARMOR 

PROGRAM USED PROGRAM DEREZED



PER	SPD	ATK	DEF	REZ
-	-	0	0	7

Lowers all brain damage by 4, as long as this Program remains Rezzed. Only 1 copy can be running at a time. Each copy can only be used once per Netrun.

Cost: 50eb Page 203

Icons by game-icons.net Circuit designed by Freepik

PROGRAM REZZED

FLAK 

PROGRAM USED PROGRAM DEREZED

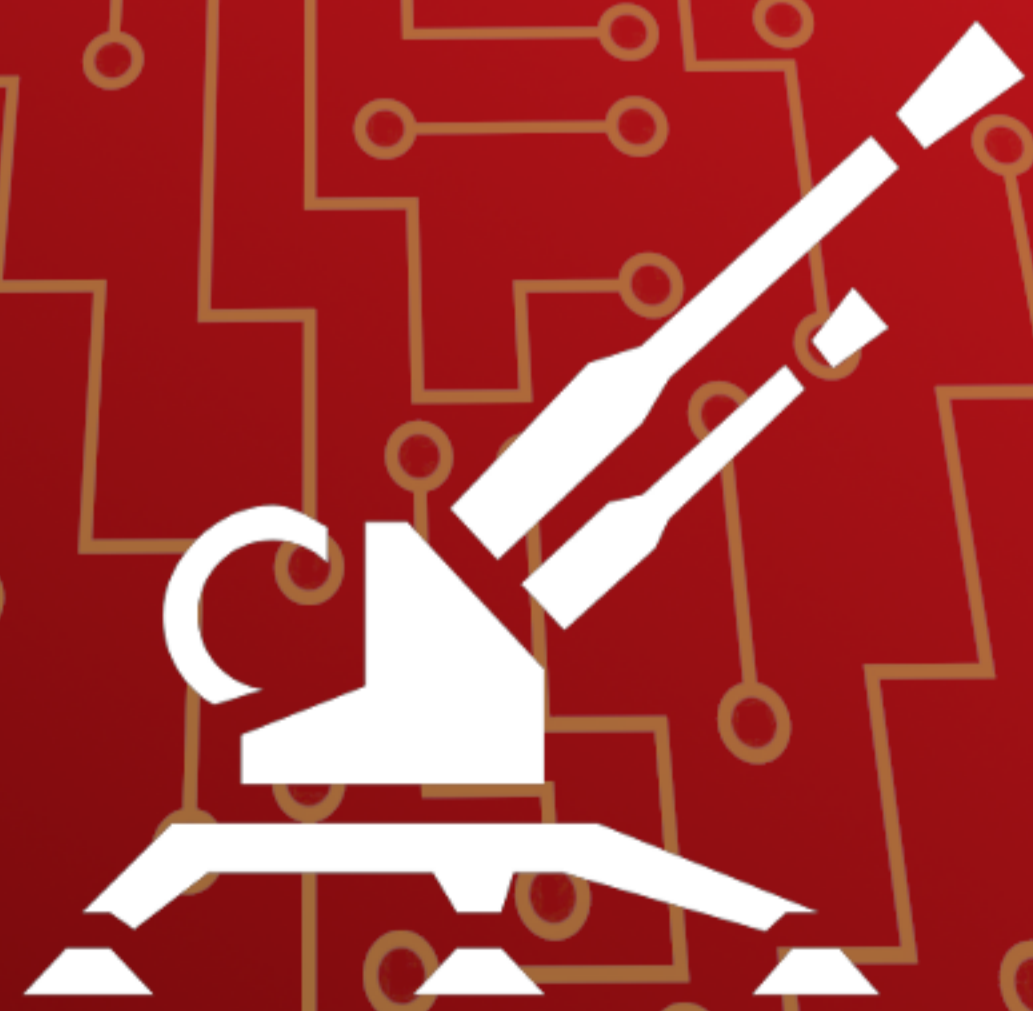

PER	SPD	ATK	DEF	REZ
-	-	0	0	7

Reduces the ATK of all Non-Black ICE Attacker Programs run against you to 0 as long as Rezzed. Only 1 copy can be running at a time. Each copy can only be used once per Netrun.

Cost: 50eb Page 203

Icons by game-icons.net Circuit designed by Freepik

PROGRAM REZZED

SHIELD 

PROGRAM USED PROGRAM DEREZED



PER	SPD	ATK	DEF	REZ
-	-	0	0	7

Stops the first successful Non-Black ICE Program Effect from dealing brain damage. After that, the Shield Derezzes itself. Only 1 copy can be running at a time. Each copy can only be used once per Netrun.

Cost: 20eb Page 203

Icons by game-icons.net Circuit designed by Freepik

PROGRAM REZZED

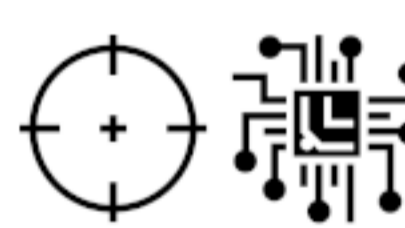
BANHAMMER 

PROGRAM USED PROGRAM DEREZED



PER	SPD	ATK	DEF	REZ
-	-	1	0	0

Does 3d6 REZ to a Non-Black ICE Program, or 2d6 REZ to a Black ICE Program.

Cost: 50eb Page 203

Icons by game-icons.net Circuit designed by Freepik

PROGRAM REZZED

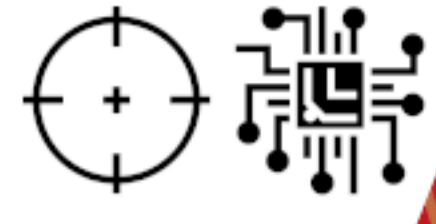
SWORD 

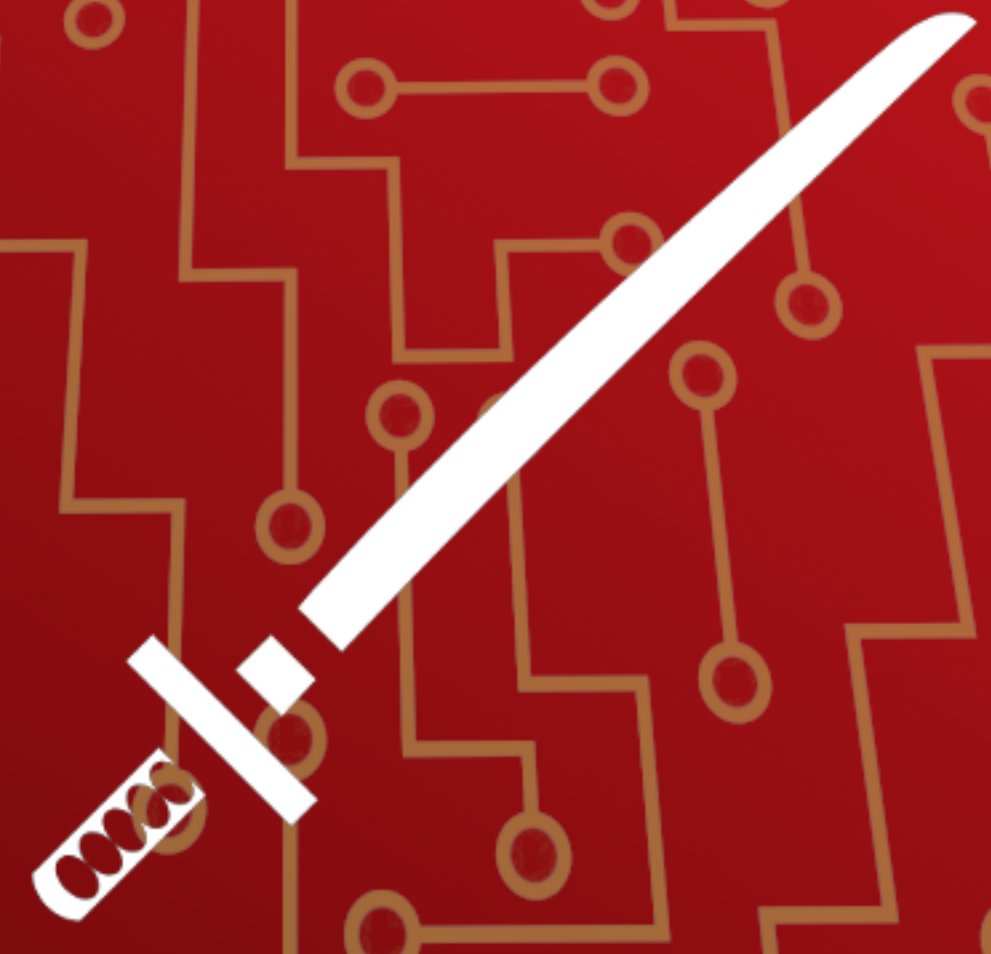
PROGRAM USED  PROGRAM DEREZED

PER	SPD	ATK	DEF	REZ
-	-	1	0	0

Does 3d6 REZ to a Black ICE Program, or 2d6 REZ to a Non-Black ICE Program.

Cost: 50eb Page 204

Icons by game-icons.net Circuit designed by Freepik

PROGRAM REZZED

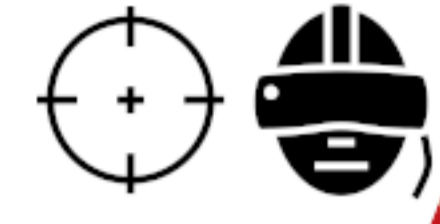
DECKKRASH 

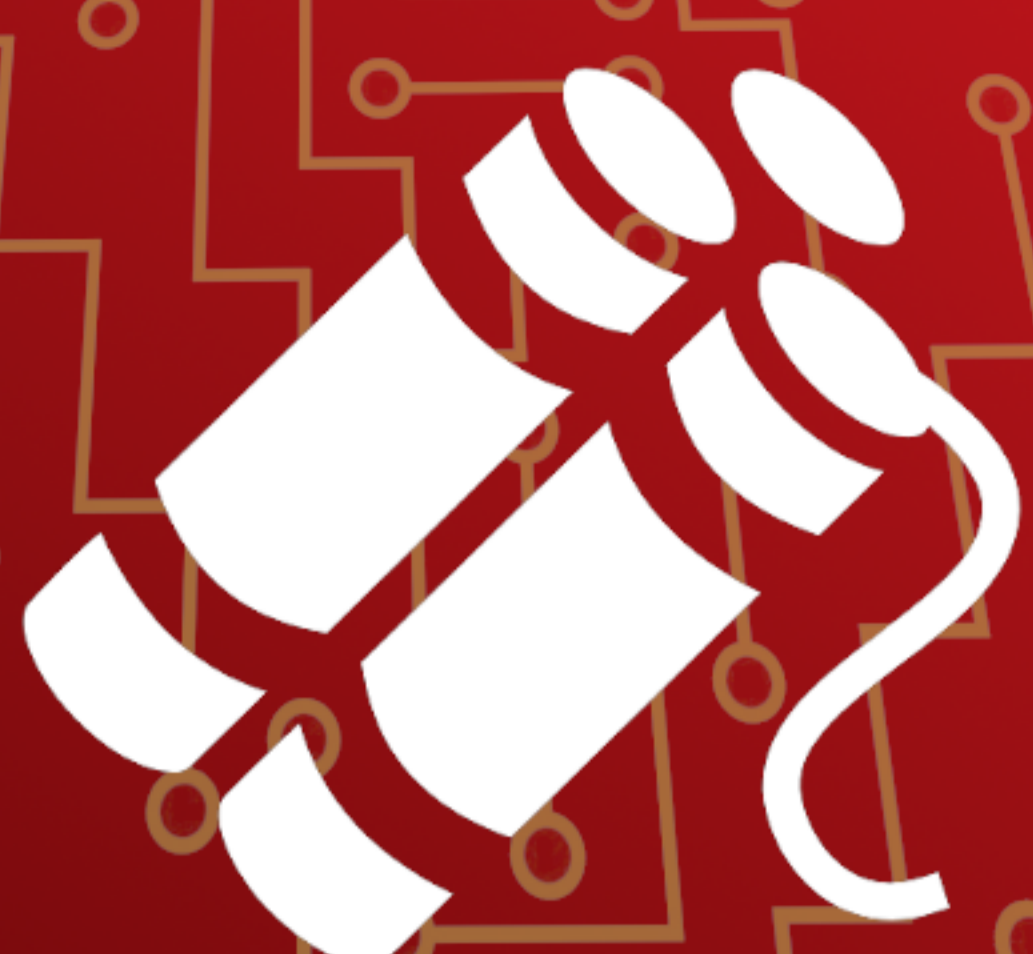
PROGRAM USED  PROGRAM DEREZED

PER	SPD	ATK	DEF	REZ
-	-	0	0	0

Enemy Netrunner is forcibly and unsafely Jacked Out, suffering the effect of all Rezzed enemy Black ICE they've encountered in the Architecture.

Cost: 100eb Page 204

Icons by game-icons.net Circuit designed by Freepik

PROGRAM REZZED

HELLBOLT 

PROGRAM USED  PROGRAM DEREZED

PER	SPD	ATK	DEF	REZ
-	-	2	0	0

Does 2d6 Damage direct to the enemy Netrunner's brain. Unless insulated, their Cyberdeck catches fire. Spend a Meat Action to put out or take 2 damage whenever they end their Turn. Does not stack.

Cost: 100eb Page 204

Icons by game-icons.net Circuit designed by Freepik

PROGRAM REZZED

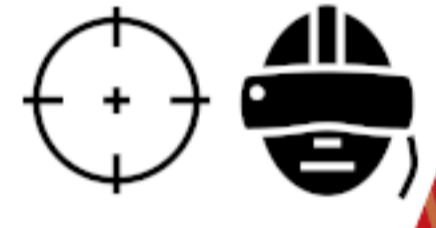
NERVESCRUB 

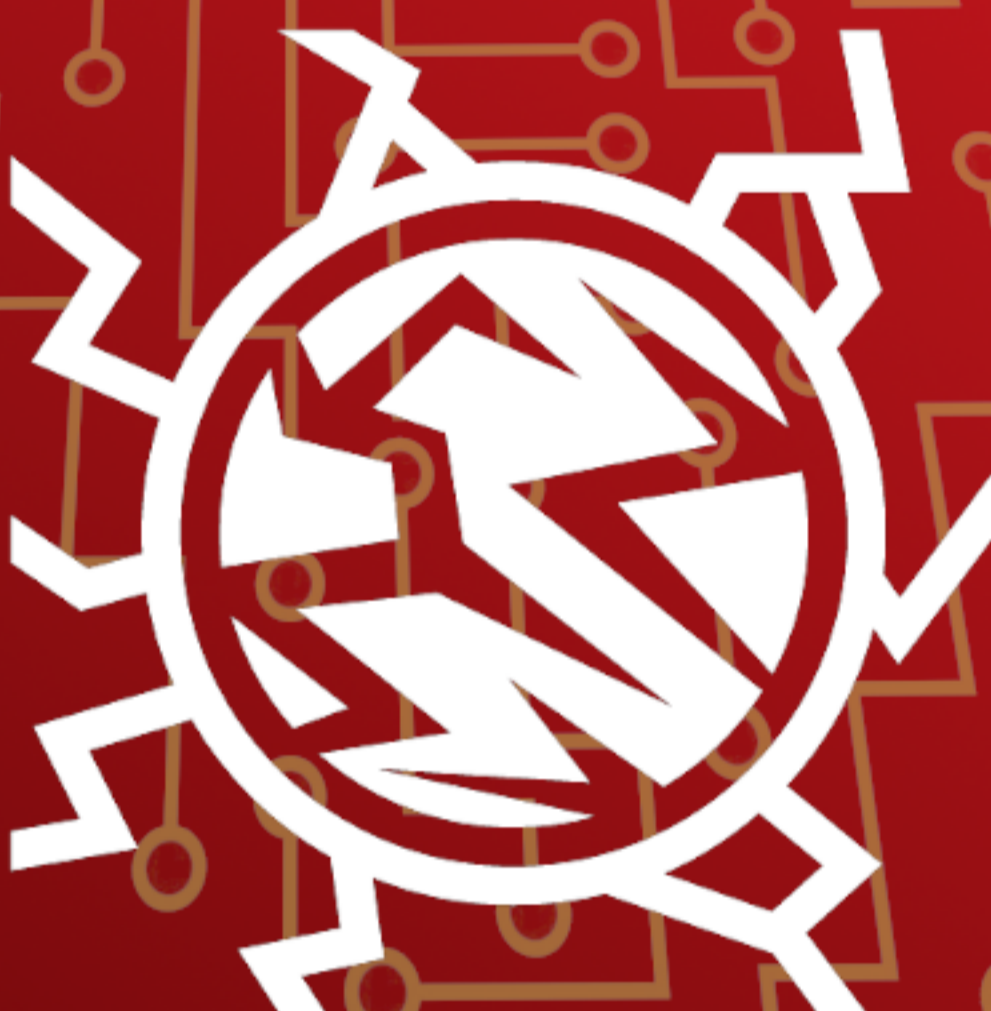
PROGRAM USED  PROGRAM DEREZED

PER	SPD	ATK	DEF	REZ
-	-	0	0	0

Enemy Netrunner's INT, REF, and DEX are each lowered by 1d6 for the next hour (minimum 1). Leaves no permanent effects.

Cost: 100eb Page 204

Icons by game-icons.net Circuit designed by Freepik

PROGRAM REZZED

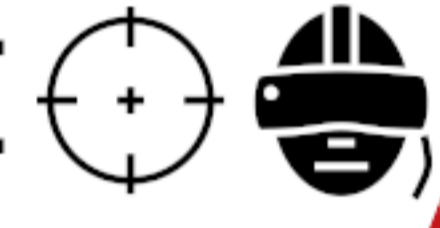
POISON FLATLINE 

PROGRAM USED  PROGRAM DEREZED

PER	SPD	ATK	DEF	REZ
-	-	0	0	0

Destroys a single Non-Black ICE Program installed on the Netrunner target's Cyberdeck at random.

Cost: 100eb Page 204

Icons by game-icons.net Circuit designed by Freepik

PROGRAM REZZED

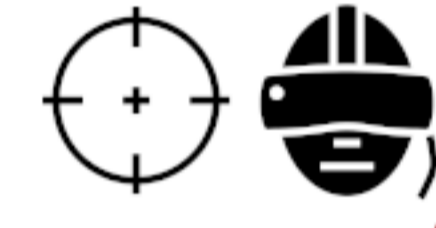
SUPERGLUE 

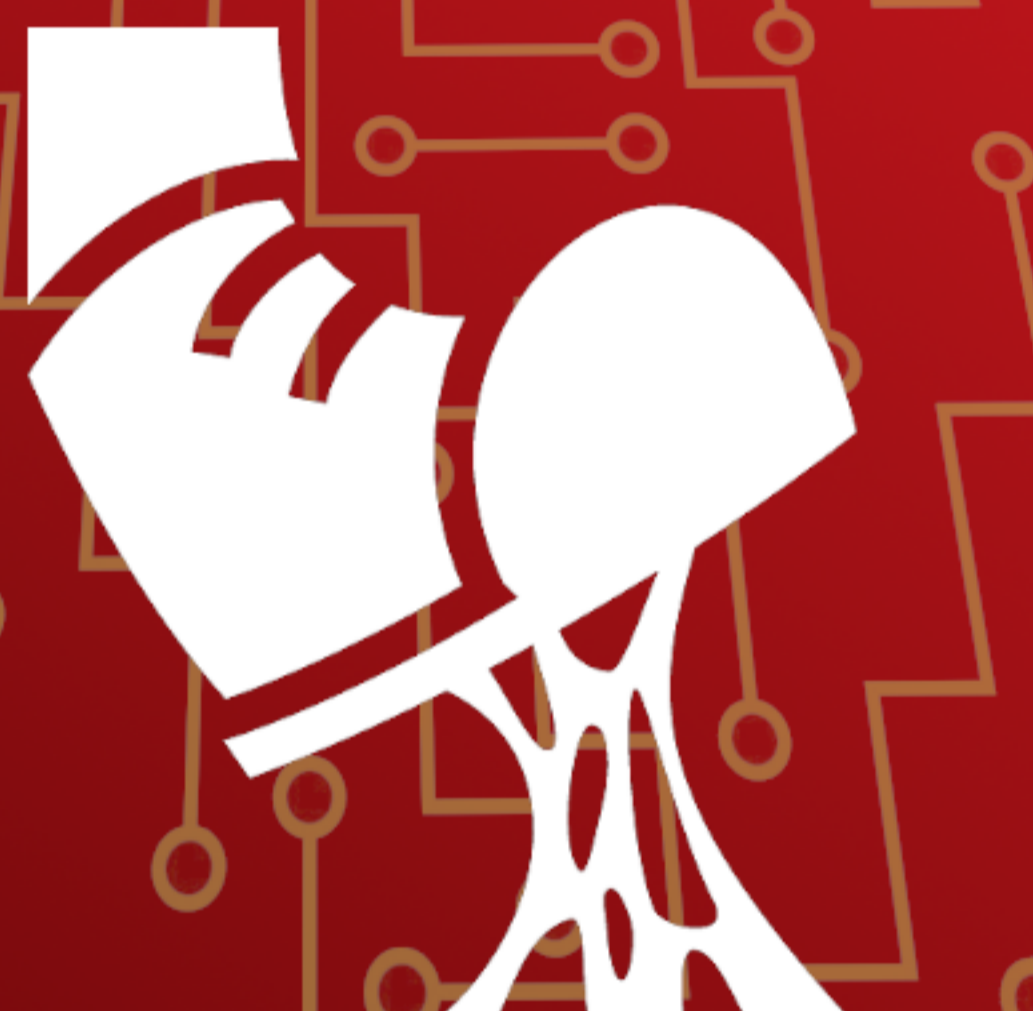
PROGRAM USED  PROGRAM DEREZED

PER	SPD	ATK	DEF	REZ
-	-	2	0	0

Enemy Netrunner cannot progress deeper into the Architecture or Jack Out safely for 1d6 Rounds. He can still Jack Out unsafe. Each copy can only be used once per Netrun.

Cost: 100eb Page 204

Icons by game-icons.net Circuit designed by Freepik

PROGRAM REZZED

VRIZZBOLT 

PROGRAM USED  PROGRAM DEREZED

PER	SPD	ATK	DEF	REZ
-	-	1	0	0

Does 1d6 Damage direct to a Netrunner's brain and lowers the amount of its NET Actions on their next Turn by 1 (min. 2).

Cost: 50eb Page 204

Icons by game-icons.net Circuit designed by Freepik

PROGRAM REZZED

ASP 

PROGRAM USED  PROGRAM DEREZED

PER	SPD	ATK	DEF	REZ
4	6	2	2	15

Destroys a single Program installed on the enemy Netrunner's Cyberdeck at random.

Cost: 100eb Page 206

Icons by game-icons.net Circuit designed by Freepik

PROGRAM REZZED

GIANT 

PROGRAM USED  PROGRAM DEREZED

PER	SPD	ATK	DEF	REZ
2	2	8	4	25

Does 3d6 damage direct to an Netrunner's brain. The Netrunner is forcibly and unsafely Jacked Out, suffering the effect of all Rezzed Black ICE they've encountered, not including the Giant.

Cost: 1,000eb Page 206

Icons by game-icons.net Circuit designed by Freepik

PROGRAM REZZED

HELLHOUND

PROGRAM USED PROGRAM DEREZZED



PER	SPD	ATK	DEF	REZ
6	6	6	2	20

Does 2d6 damage direct to the Netrunner's brain. Unless insulated, their Cyberdeck catches fire. Until they spend a Meat Action, they take 2 damage whenever they end their Turn. Does not stack.

Cost: 500eb Page 206

Icons by game-icons.net Circuit designed by Freepik

PROGRAM REZZED

KRAKEN

PROGRAM USED PROGRAM DEREZZED



PER	SPD	ATK	DEF	REZ
6	2	8	4	30

Does 3d6 damage direct to an enemy Netrunner's brain. Until the end of the next Turn, he cannot progress deeper or Jack Out safely. He can still Jack Out unsafe.

Cost: 1,000eb Page 207

Icons by game-icons.net Circuit designed by Freepik

PROGRAM REZZED

LICHE

PROGRAM USED PROGRAM DEREZZED



PER	SPD	ATK	DEF	REZ
8	2	6	2	25

Enemy Netrunner's INT, REF, and DEX are each lowered by 1d6 for the next hour (minimum 1). Leaves no permanent effects.

Cost: 500eb Page 207

Icons by game-icons.net Circuit designed by Freepik

PROGRAM REZZED

RAVEN

PROGRAM USED PROGRAM DEREZZED



PER	SPD	ATK	DEF	REZ
6	4	4	2	15

Derezzes a single Defender Program the enemy Netrunner has Rezzed at random, then deals 1d6 damage direct to the Netrunner's brain.

Cost: 50eb Page 207

Icons by game-icons.net Circuit designed by Freepik

PROGRAM REZZED

SCORPION

PROGRAM USED PROGRAM DEREZZED



PER	SPD	ATK	DEF	REZ
2	6	2	2	15

Enemy Netrunner's MOVE is lowered by 1d6 for the next hour (minimum 1). Leaves no permanent effects.

Cost: 100eb Page 207

Icons by game-icons.net Circuit designed by Freepik

PROGRAM REZZED

SKUNK

PROGRAM USED PROGRAM DEREZZED



PER	SPD	ATK	DEF	REZ
2	4	4	2	10

Until this Ice is Derezzed, an enemy Netrunner hit makes all Slide Checks at -2. Each Skunk can only affect one Netrunner at a time, but the effects of multiple Skunks can stack.

Cost: 500eb Page 207

Icons by game-icons.net Circuit designed by Freepik

PROGRAM REZZED

WISP

PROGRAM USED PROGRAM DEREZZED



PER	SPD	ATK	DEF	REZ
4	4	4	2	15

Does 1d6 damage direct to the enemy Netrunner's brain and lowers the NET Actions on their next Turn by 1 (minimum 2).

Cost: 50eb Page 207

Icons by game-icons.net Circuit designed by Freepik

PROGRAM REZZED

DRAGON

PROGRAM USED PROGRAM DEREZZED



PER	SPD	ATK	DEF	REZ
6	4	6	6	30

Deals 6d6 damage to a Program. If this damage would be enough to Derezz the Program, it is instead Destroyed.

Cost: 1,000eb Page 207

Icons by game-icons.net For private use only!

PROGRAM REZZED

KILLER

PROGRAM USED PROGRAM DEREZZED

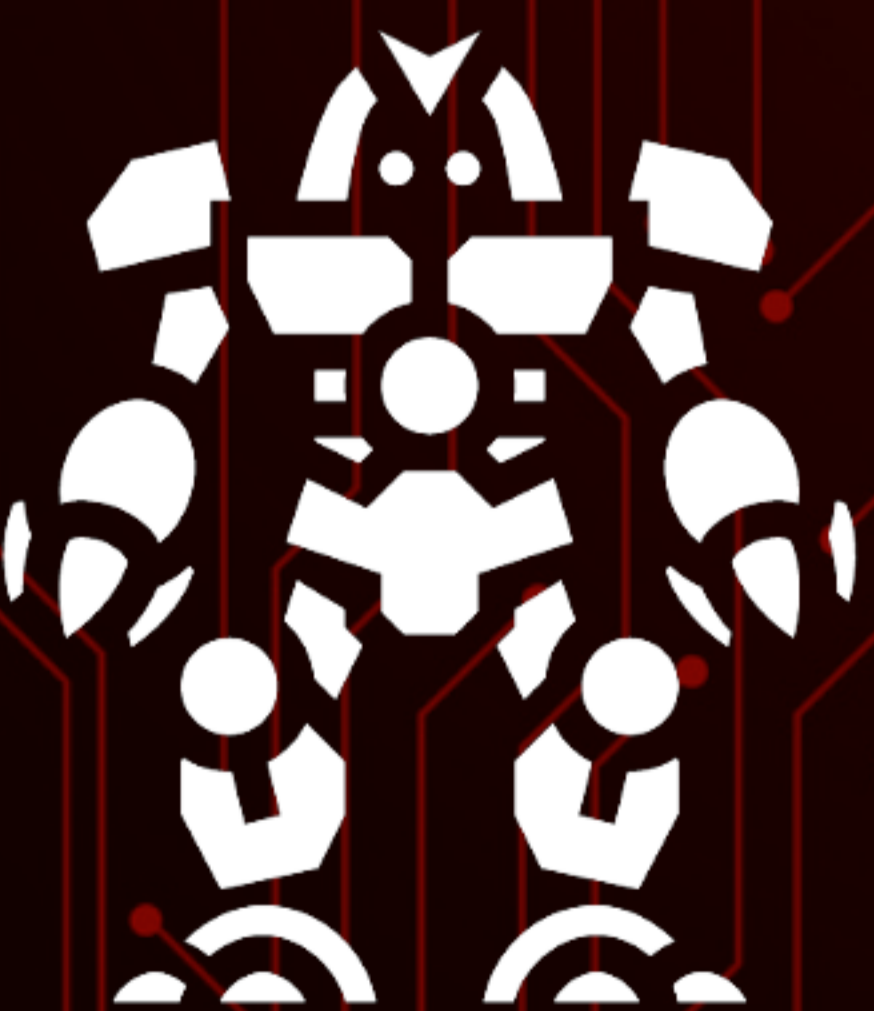

PER	SPD	ATK	DEF	REZ
4	8	6	2	20

Deals 4d6 damage to a Program. If this damage would be enough to Derezz the Program, it is instead Destroyed.

Cost: 500eb Page 207

Icons by game-icons.net For private use only!

PROGRAM REZZED

SABRETOOTH



PROGRAM USED

PROGRAM DEREZZED

PER	SPD	ATK	DEF	REZ
8	6	6	2	25

Deals 6d6 damage to a Program. If this damage would be enough to Derezz the Program, it is instead Destroyed.

Cost: 1,000eb

Page 207

Icons by game-icons.net

Circuit designed by Freepik

Control



LVL

DV

Use CONTROL to take over node.

Activating the controlled device required a separate Net Action. Each Control Node can only be activated once per Turn.

Icons by game-icons.net

For private use only!

File



LVL

DV

Use EYE DEE to get more information.

Saving a Copy of a File is not a Net Action.

Icons by game-icons.net

For private use only!

Password

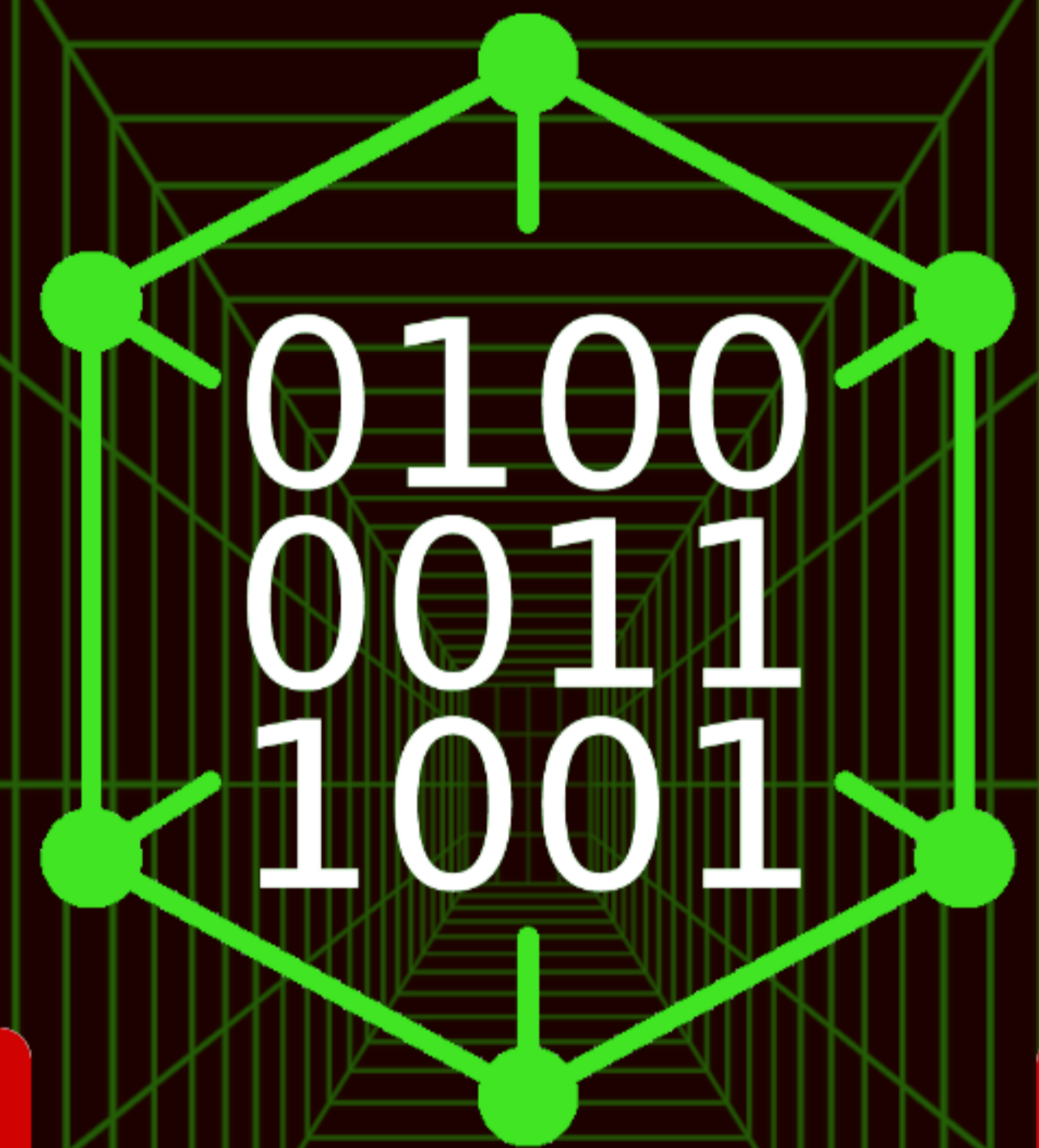

LVL

DV

Use BACKDOOR to break Password, unless you already know the correct code.

Icons by game-icons.net

For private use only!

Branch

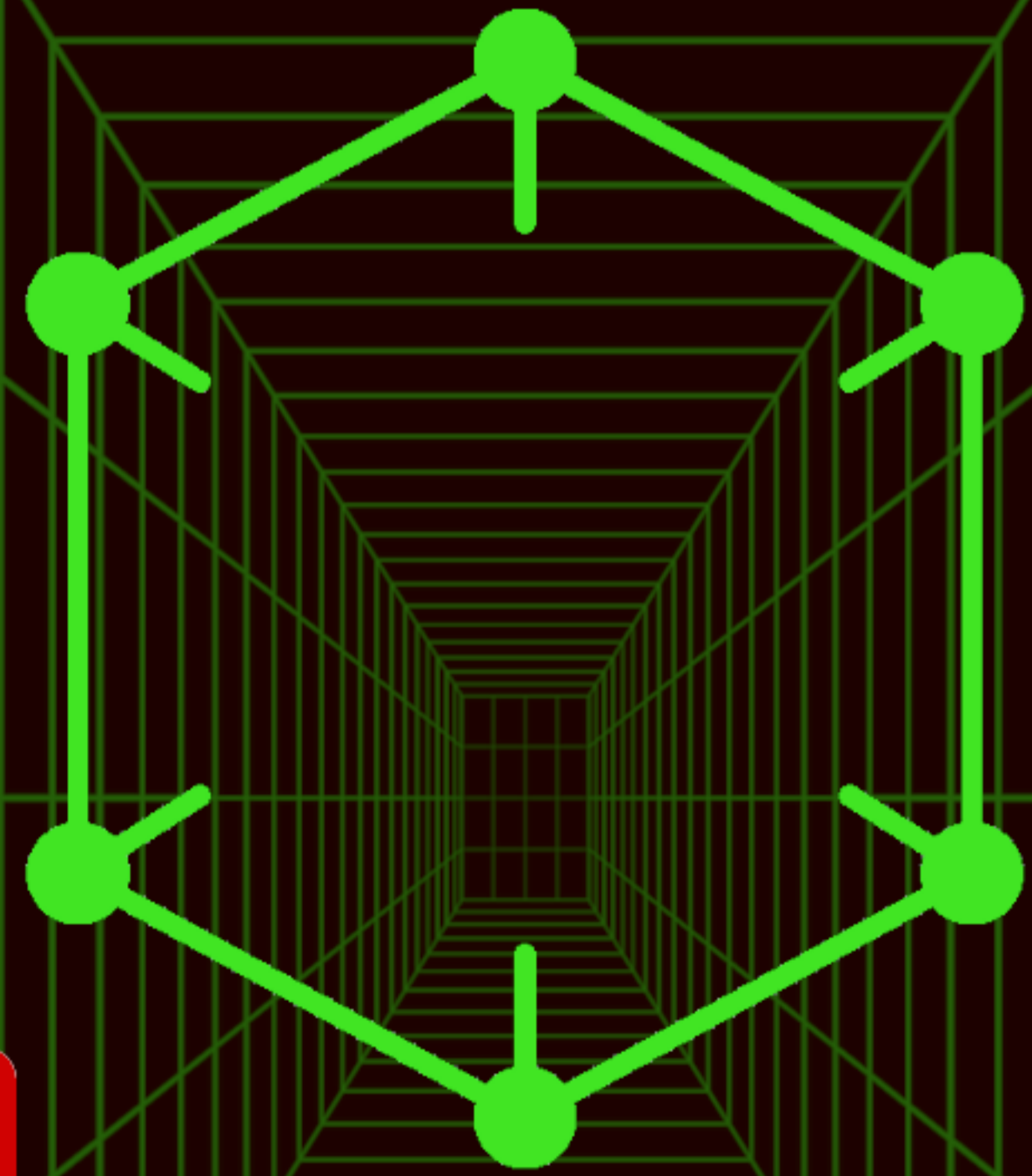

LVL

DV

Enter Branch to get more information.

Icons by game-icons.net

For private use only!

Branch

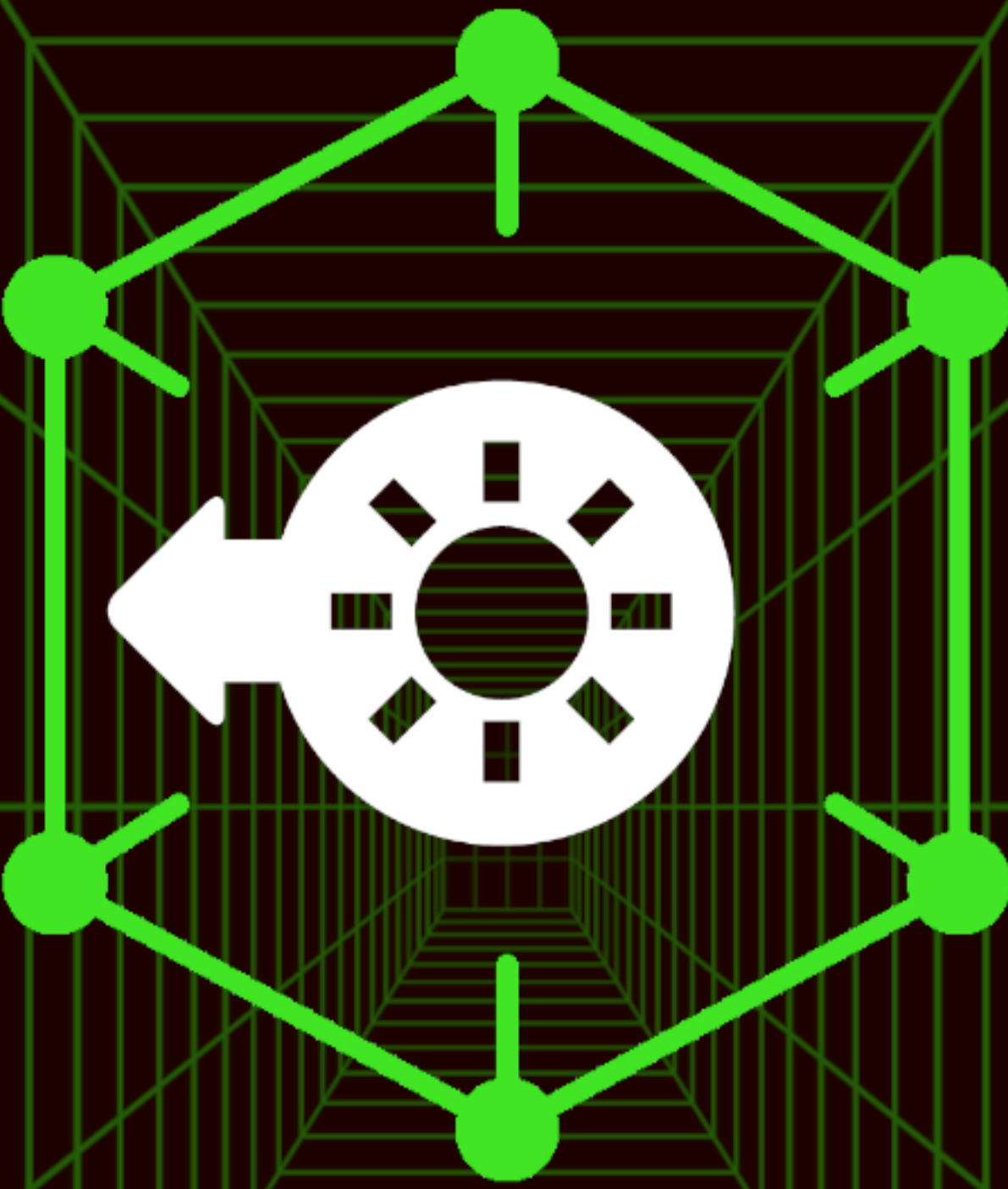

LVL

DV

Enter Branch to get more information.

Icons by game-icons.net

For private use only!

Branch

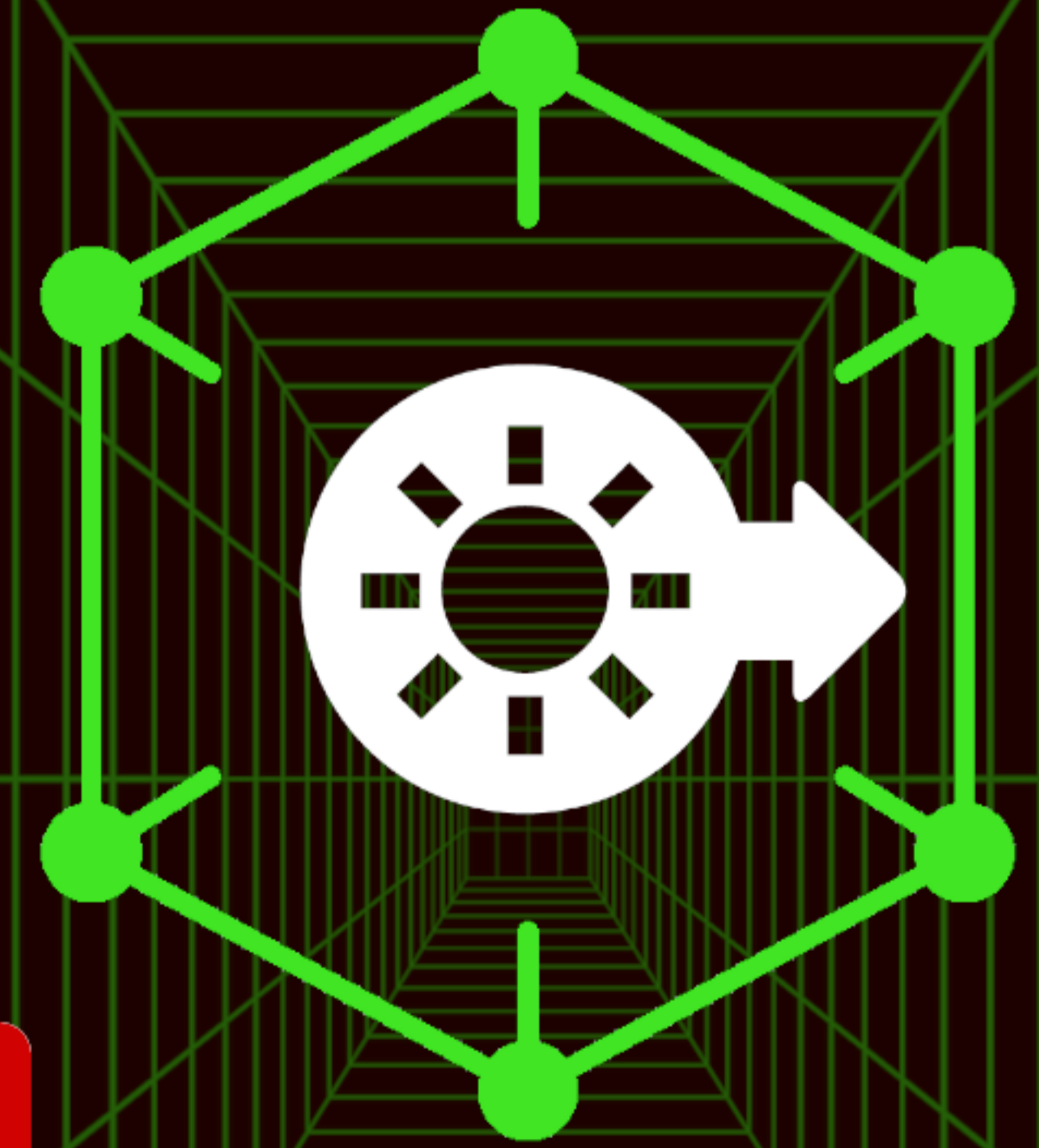

LVL

DV

Enter Branch to get more information.

Icons by game-icons.net

For private use only!

PROGRAM REZZED

IMP 

PROGRAM USED  PROGRAM DEREZED

REZ	Interface	NET Actions	Combat Number
15	3	2	14

Immune to SLIDE actions.

Cost: 1,000eb Page 212

Icons by game-icons.net Circuit designed by Freepik

PROGRAM REZZED

EFREET 

PROGRAM USED  PROGRAM DEREZED

REZ	Interface	NET Actions	Combat Number
25	4	3	14

Immune to SLIDE actions.

Cost: 5,000eb Page 212

Icons by game-icons.net Circuit designed by Freepik

PROGRAM REZZED

BALRON 

PROGRAM USED  PROGRAM DEREZED

REZ	Interface	NET Actions	Combat Number
30	7	4	14

Immune to SLIDE actions.

Cost: 10,000eb Page 212

Icons by game-icons.net Circuit designed by Freepik